

YUME DX

QUICK OPERATION GUIDE



For details and safety information
see the operating instructions.

<https://manual.tb-global.net/>



1 Foot Control/ Power Switch

EX-YM2XL : left side foot control

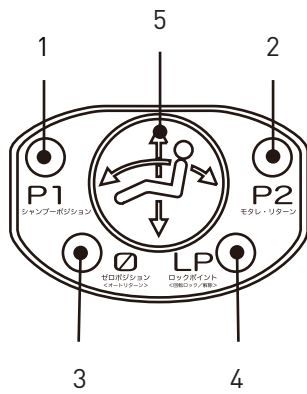

EX-YM2XR : right side foot control

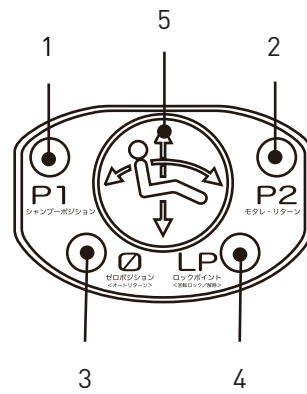

1 P1 Switch

 Preset position 1 (Used mainly for shampooing position)

2 P2 Switch

 Preset Position 2 (Used mainly with the backrest upright)

How to set the preset position

- 1) P1: Set the chair to the desired position
P2: Set the chair backrest to the desired position
- 2) Turn off the main switch
- 3) While depressing the Preset Switch (P1 or P2), turn on the main switch
- 4) Keep depressing the Preset Switch until the buzzer sounds, then release

3 Auto Return Switch

 Chair will move to the initial position automatically

4 Lock Position Switch

 Lock/unlock the chair rotating position

5 Manual Mode Control

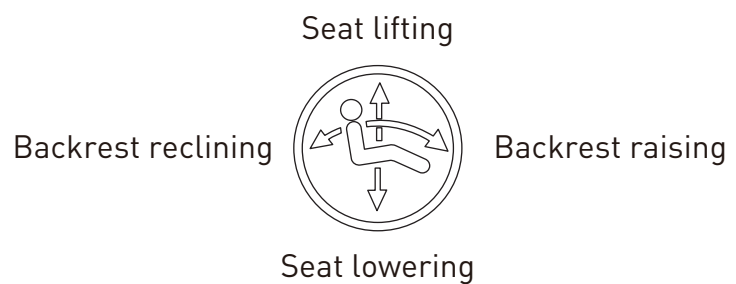

Legrest Switch

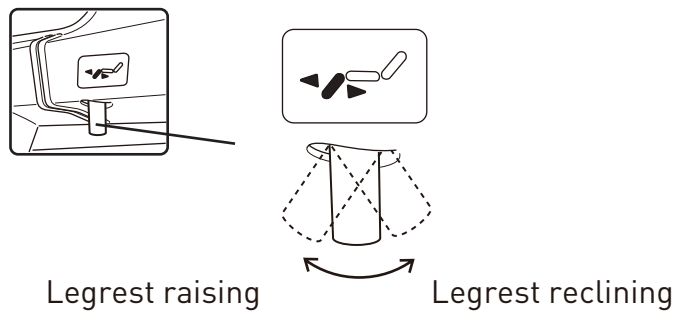

Headrest

Headrest Handle

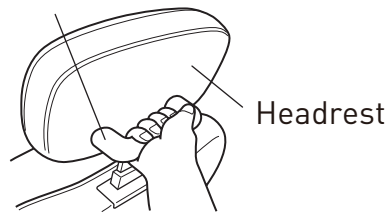

Remove the headrest when not in use



Shampoo Basin

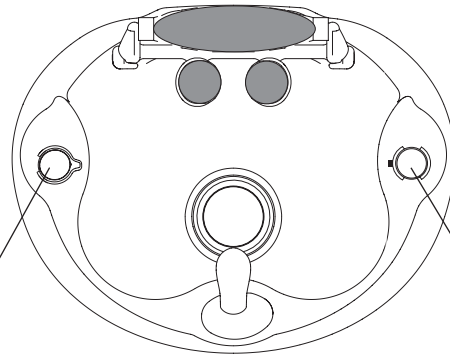

Tap

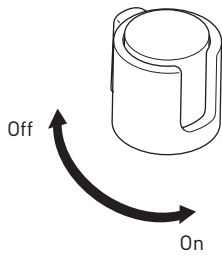

Thermostatic Control

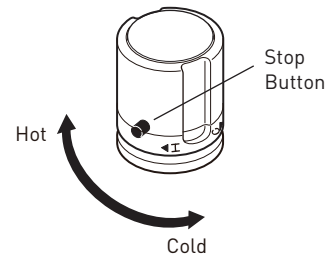

To adjust the temperature over 40 degrees, turn the knob while pressing the Stop Button

Drain Cap (Old)



Drain Cap (New)

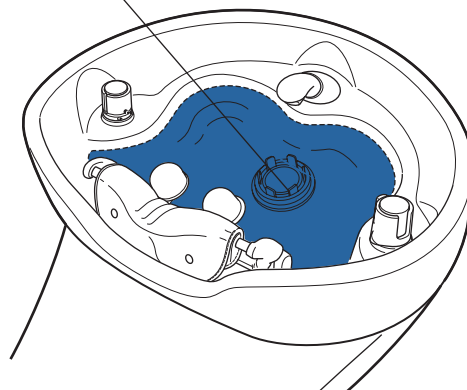
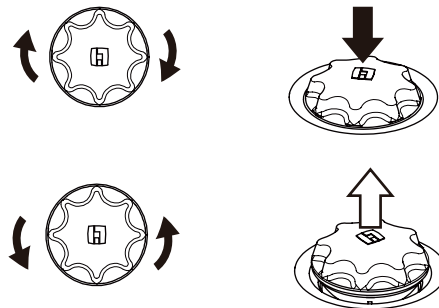

<YUME shower head>

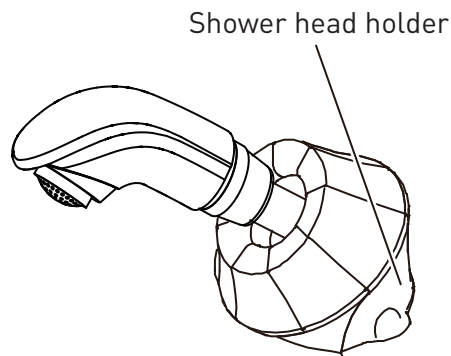

Shower Head Holder

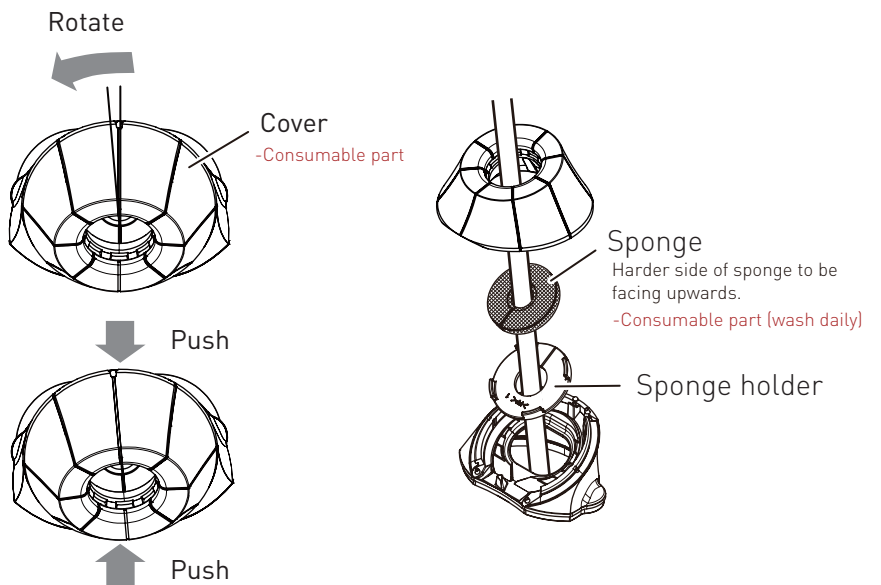

1 Attach the Neck Cushion and Head Pillow.

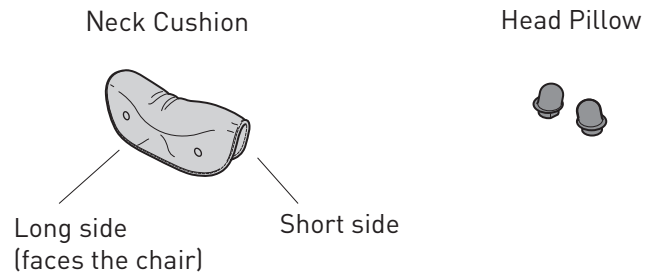

2 Attach both sides of the Neck Cushion with snap button.

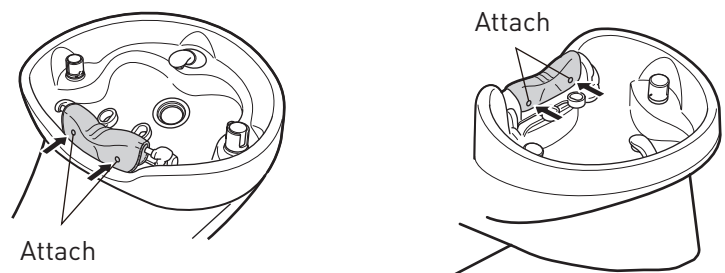

3 Attach the head pillow as shown below.

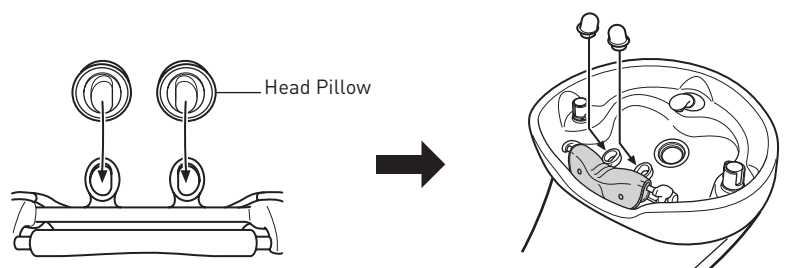

6 Operation procedures

- 1 Turn on the power.

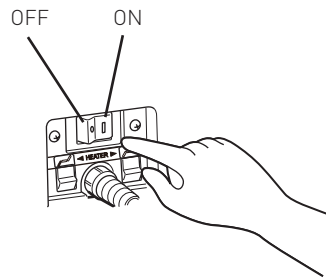

- 2 Press the auto return switch to bring the chair to its initial position.

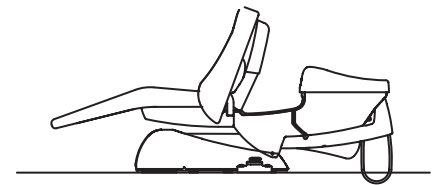
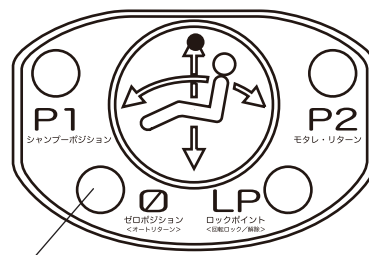

Initial Position

Auto Return Switch

- 3 Instruct the customer to sit from the side, then face front.

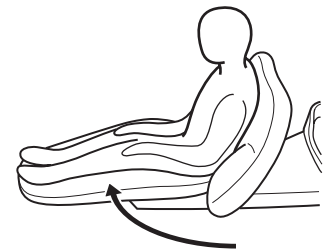
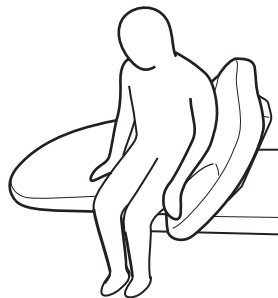

- 4 Press the P1 switch (or manual mode control) to bring the chair to its approximate position.

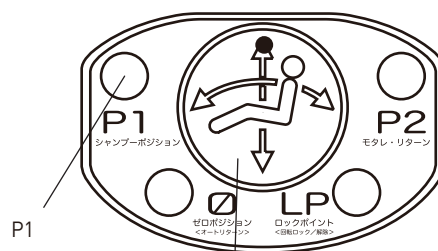

Manual Mode Control

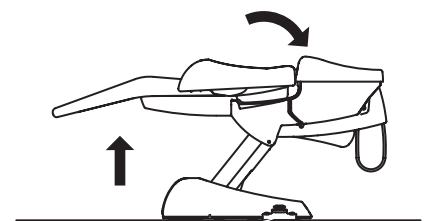

Preset Position

5 Adjust the chair height.

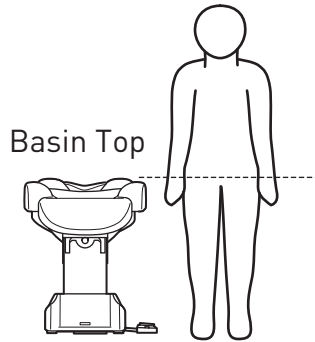

The basin top height should match the practitioner's hip

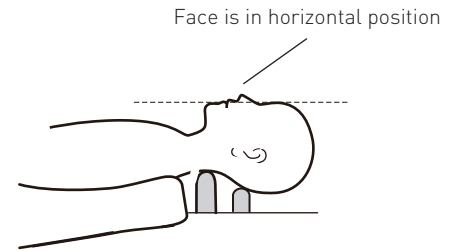

CAUTION

Confirm that there are no objects/people between the seat/shampoo basin and the floor when operating the chair.

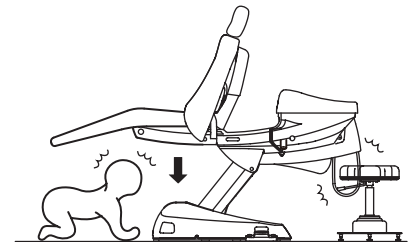

<Shampooing Style>

<Sitting position>

<Standing position>



Rear Shampoo



Side Shampoo



- 6 After the shampooing, return the chair to its initial position.

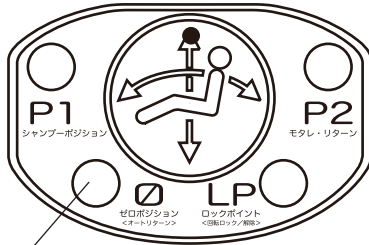

Auto Return Switch

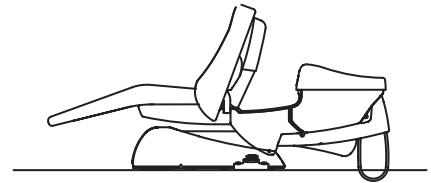

Initial Position

- 7 Wipe off the remaining water after use.

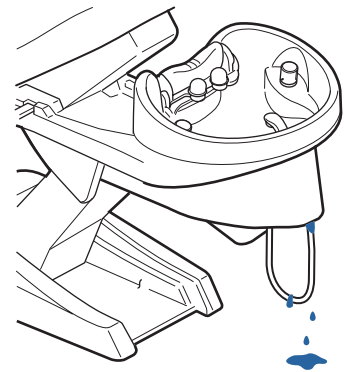
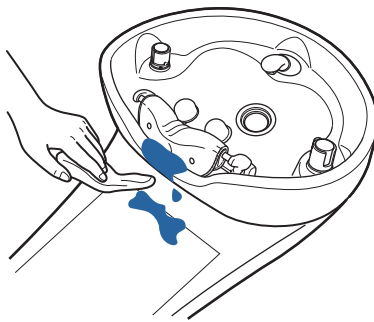

- 8 Clean the consumable parts.

Neck Cushion

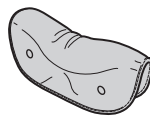

Head Pillow



Drain Cap

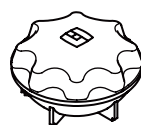

Hair Catcher

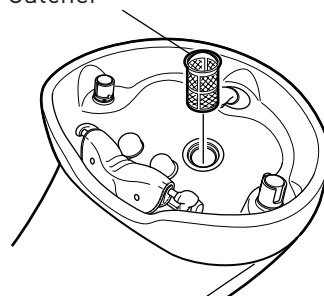

7 Rotating the chair

- 1 Press the P2 switch to bring the backrest to its upright position.

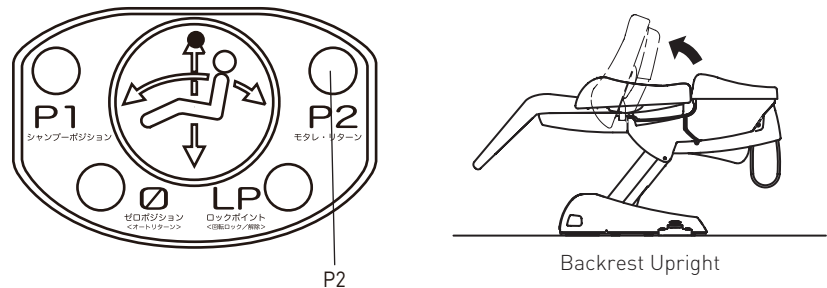

- 2 Press the lock position switch to unlock the chair rotation.

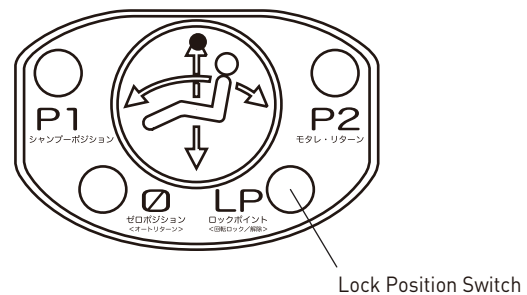

The chair lock will not release when the backrest is within 30 degrees.

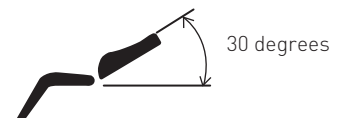

- 3 Rotate the chair to the desired position by gently holding onto the backrest
⇒ A clicking sound can be heard at the 60 and 90 degrees point

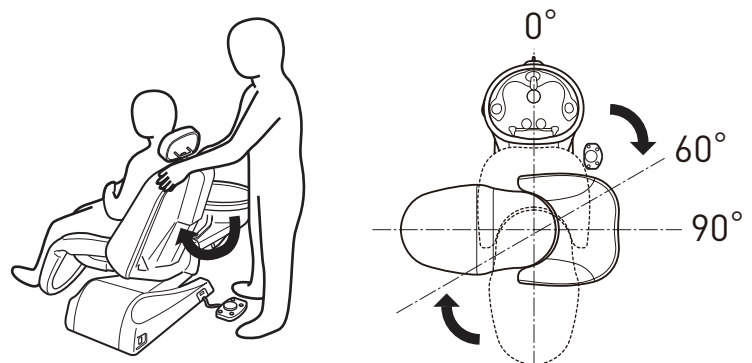

- 4 Press the lock position switch to lock the chair rotation.

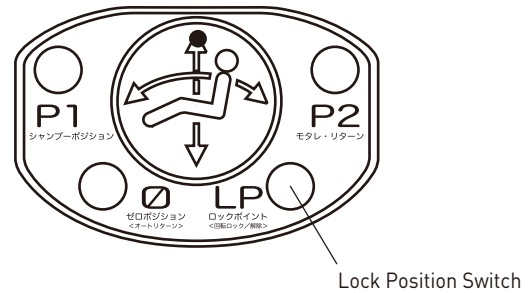

CAUTION

Confirm that there are no objects/people in the way when rotating the chair.

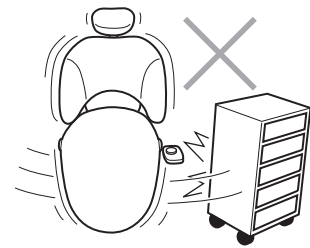

- 5 When finished, unlock the chair to return it to its initial position (0°), and lock.

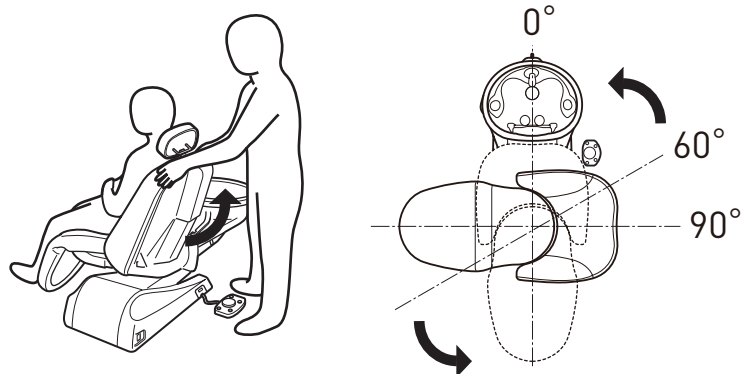



TAKARA BELMONT CORPORATION

2-1-1, Higashishinsaibashi, Chuo-ku, Osaka, 542-0083, Japan

TEL : 81-6-6213-5945

FAX : 81-6-6212-3680

